

**ALERT FIRE CO.**  
**DOWNINGTOWN, PA**

S0.137320

AERIAL BODY  
 CYCLONE II X CHASSIS  
 HP95' AERIAL PLATFORM

THIS DRAWING IS FOR REFERENCE PURPOSES. ALL DIMENSIONS ARE  
 SUBJECT TO MINOR VARIATIONS DUE TO MANUFACTURING PROCESSES.

**APPROVED FOR PRODUCTION**

DESIGNER: B. MASON DATE: 2012-APR-27

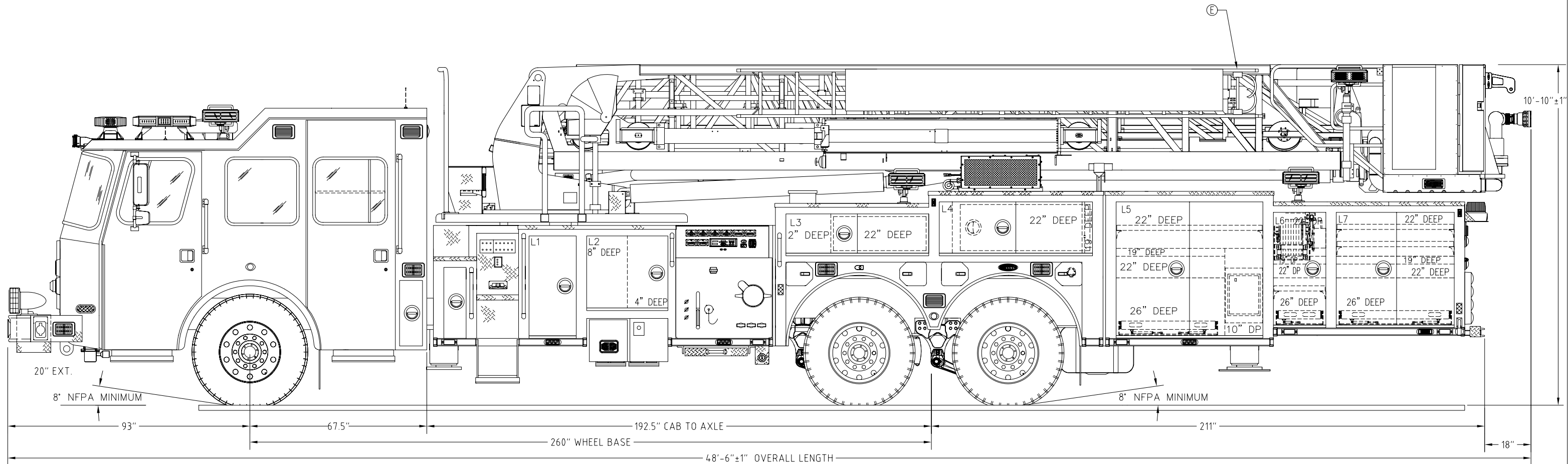
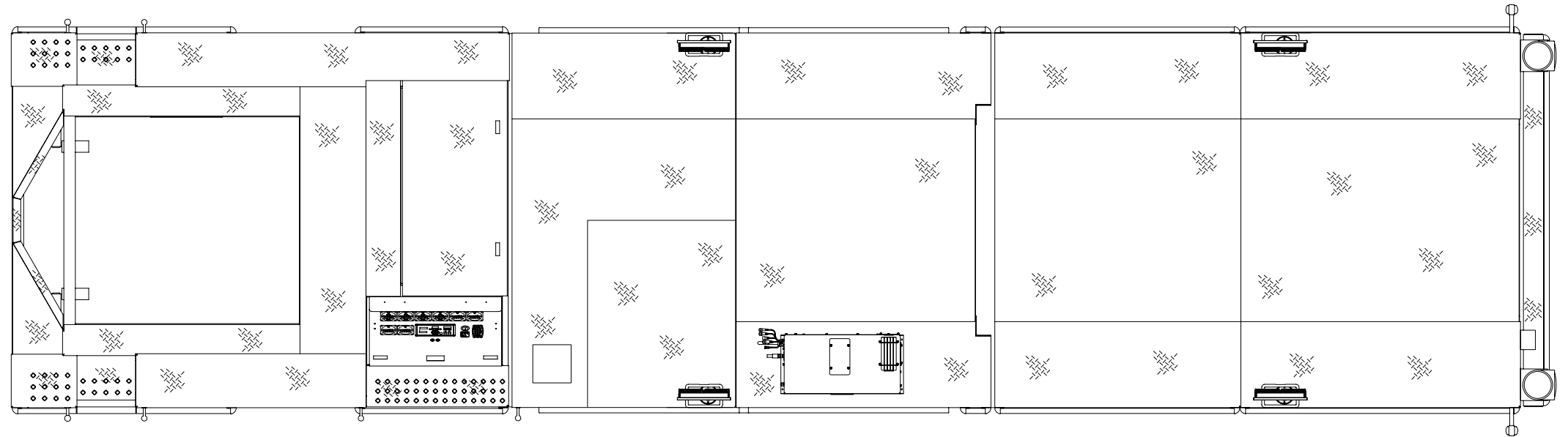

TGB	D	REV	2012-MAY-9	BEM
TGB	C	RFP	2012-APR-30	BEM
TGB	B	RFC	2012-MAR-29	BEM
TGB	A	INITIAL RELEASE	2012-JAN-20	BEM
DRAWN BY	REV	DESCRIPTION	DATE	APPROVED
APPROVAL REVISIONS				SHEET 1 OF 2

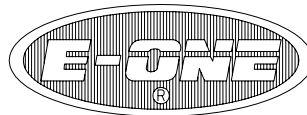

# ALERT FIRE CO. DOWNTOWN, PA

so.137320

AERIAL BODY  
CYCLONE II X CHASSIS  
HP 95' AERIAL PLATFORM

2000 GPM HALE 8FGR PUMP  
130 GALLON WATER TANK

COMPT.	OPENING		INTERIOR DIMENSION		
L1	18W	38H	OIL RESEVOIR		
R1	18W	38H	18W	38H	20D
L2/R2	31W	27H	31W	27H	NOTED
L3	54W	15H	54W	15H	NOTED
R3	54W	15H	54W	15H	22D
L4/R4	58W	19H	58W	19H	NOTED
L5/R5	56W	51H	56W	17H NOTED	UPPER
			56W	30H NOTED	LOWER
L6/R6	20W	43H	20W	16H	22D UPPER
			20W	18H	26D LOWER
L7/R7	45W	43H	45W	16H	22D UPPER
			45W	18H	26D LOWER

THIS DRAWING IS FOR REFERENCE PURPOSES. ALL DIMENSIONS ARE SUBJECT TO MINOR VARIATIONS DUE TO MANUFACTURING PROCESSES.

### GROUND LADDERS

ITEM	LADDER LENGTH	MODEL NUMBER	QTY
A	35' 2-SECT.	PEL-35	2
B	28' 2-SECT.	PEL-28	2
C	24' 2-SECT.	PEL-24	1
D	20' ROOF	PRL-20	1
E	16' ROOF	PRL-16	1
F	14' ROOF	PRL-14	2
G	12' ROOF	PRL-12	1
H	10' FOLDING	FL-10	1

ON AERIAL  
ONE ON AERIAL

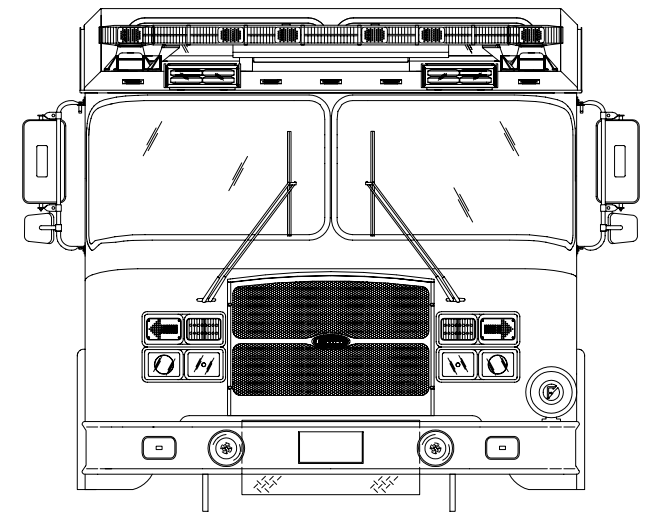
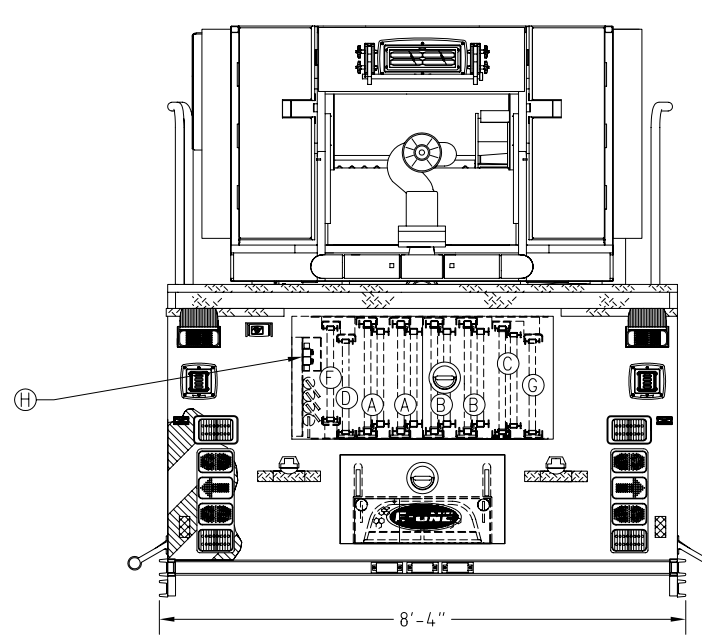

THIS DRAWING IS FOR REFERENCE PURPOSES. ALL DIMENSIONS ARE SUBJECT TO MINOR VARIATIONS DUE TO MANUFACTURING PROCESSES.

APPROVED FOR PRODUCTION

DESIGNER: B. MASON DATE: 2012-APR-27

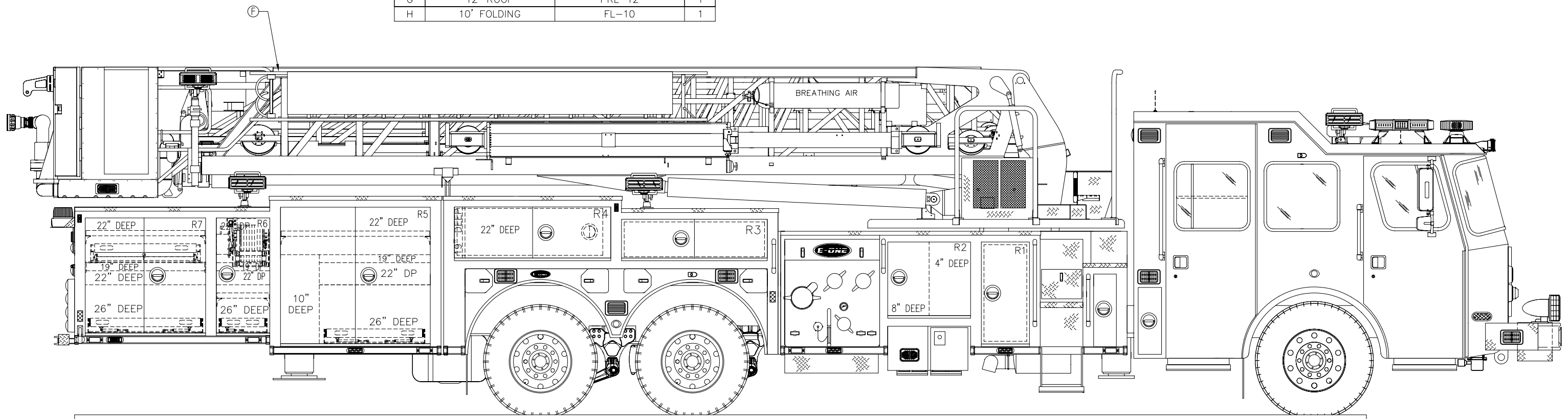

TGB	D	REV	2012-MAY-9	BEM
TGB	C	RFP	2012-APR-30	BEM
TGB	B	RFC	2012-MAR-29	BEM
TGB	A	INITIAL RELEASE	2012-JAN-20	BEM
DRAWN BY	REV	DESCRIPTION	DATE	APPROVED
APPROVAL REVISIONS				SHEET 2 OF 2