

# FAME OF WEST CHESTER WEST CHESTER, PA

SO.137117  
AERM AERIAL BODY  
CYCLONE II X CHASSIS  
CR137 AERIAL

THIS DRAWING IS FOR REFERENCE PURPOSES. ALL DIMENSIONS ARE SUBJECT TO MINOR VARIATIONS DUE TO MANUFACTURING PROCESSES.

APPROVED FOR PRODUCTION

DESIGNER: B. MASON DATE: 2011-OCT-17

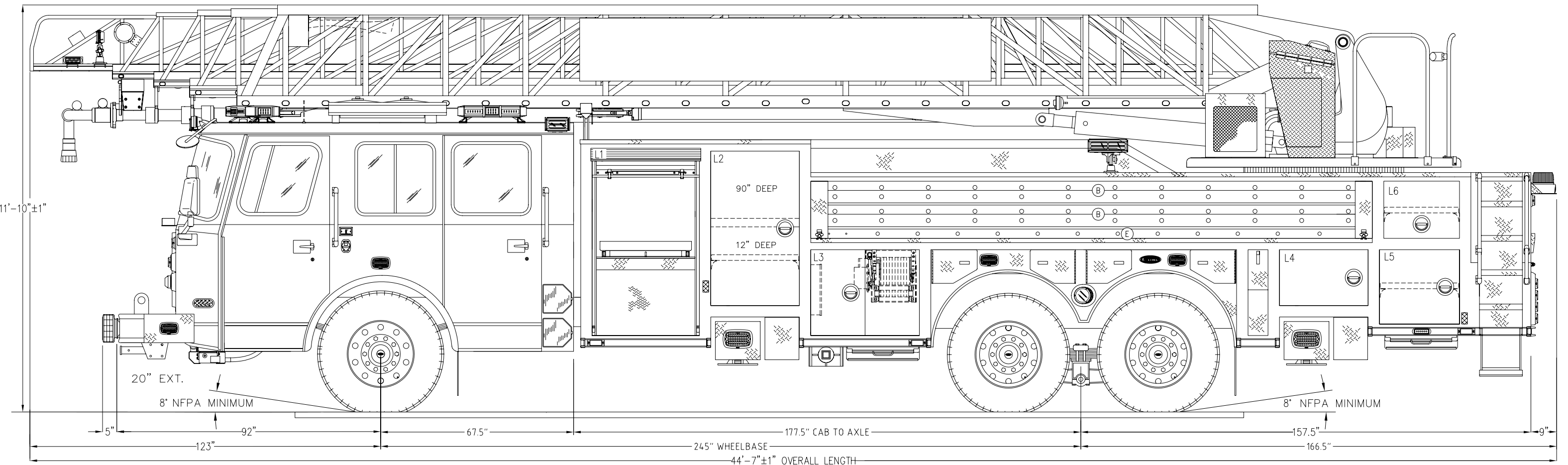
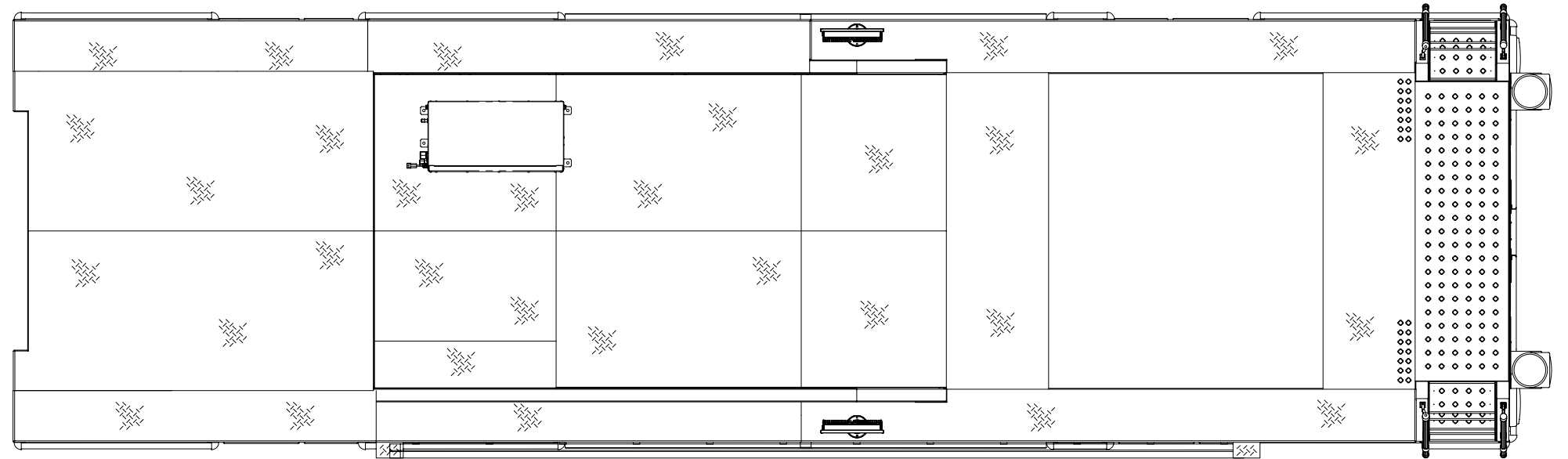

TGB E REV 2012-AUG-6 BEM

TGB	D	REV	2012-JUN-27	BEM
TGB	C	REV	2012-JUN-1	BEM
TGB	B	TRP	2011-OCT-17	BEM
TGB	A	INITIAL RELEASE	2011-SEP-20	BEM
DRAWN BY	REV	DESCRIPTION	DATE	APPROVED

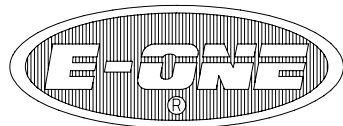

# FAME OF WEST CHESTER WEST CHESTER, PA

SO.137117  
AERM AERIAL BODY  
CYCLONE II X CHASSIS  
CR137 AERIAL

THIS DRAWING IS FOR REFERENCE PURPOSES. ALL DIMENSIONS ARE  
SUBJECT TO MINOR VARIATIONS DUE TO MANUFACTURING PROCESSES.

**APPROVED FOR PRODUCTION**

DESIGNER: B. MASON DATE: 2011-OCT-17

COMPT.	OPENING		INTERIOR DIMENSION			
L1	35W	55H	37W	40H	90D	UPPER
			37W	27H	20D	LOWER
R1	35W	55H	37W	40H	90D	UPPER
			37W	27H	9D	LOWER
L2/R2	31W	54H	31W	26H	NOTED	UPPER
			31W	27H	12D	LOWER
L3	38W	30H	38W	30H	23D	
L4	31W	19H	31W	19H	12D	
L5	28W	26H	28W	26H	22D	
L6	26W	20H	26W	20H	15D	
R3	38W	64H	38W	11H	9D	UPPER
			38W	53H	24D	LOWER
R4	50W	30H	50W	11H	9D	UPPER
			50W	19H	24D	LOWER
R5	63W	19H	63W	19H	NOTED	
R6	31W	42H	31W	19H	15D	UPPER
			31W	20H	12D	LOWER
R7	28W	49H	28W	15H	15D	UPPER
			28W	26H	22D	LOWER
B1/B2	12W	15H	12W	15H	17D	

GROUND LADDERS			
ITEM	LADDER LENGTH	MODEL NUMBER	QTY
A	35' 2-SECT.	DUO-SAFETY 1200-A	2
B	28' 2-SECT.(22"W)	DUO-SAFETY 1200-A	2
C	28' 2-SECT.	DUO-SAFETY 1200-A	1
D	18' ROOF	DUO-SAFETY 875-A	2
E	16' ROOF	DUO-SAFETY 875-A	2
F	10' FOLDING	DUO-SAFETY 585-A	1

ONE ON AERIAL

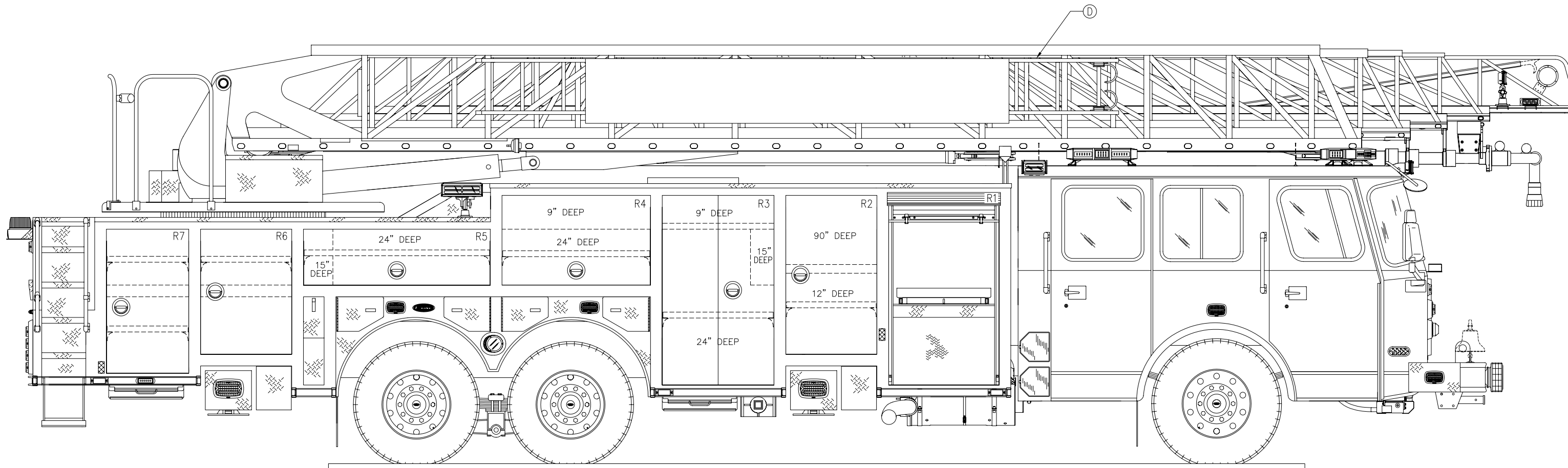
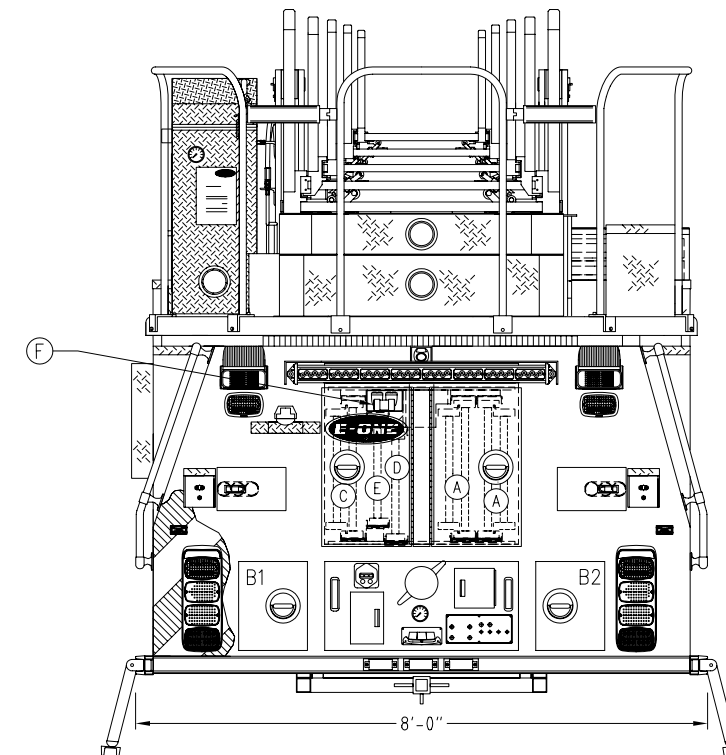
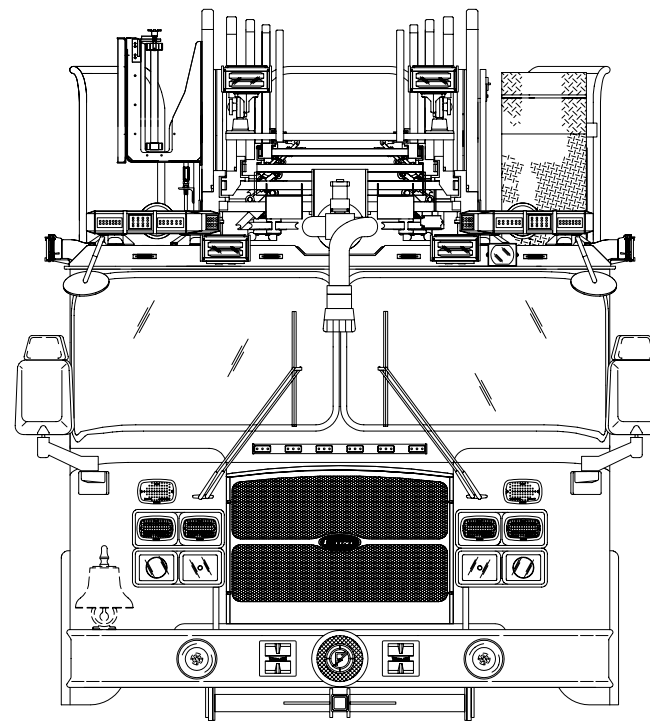

TGB	REV	DESCRIPTION	DATE	APPROVED
TGB	E	REV	2012-AUG-6	BEM
TGB	D	REV	2012-JUN-27	BEM
TGB	C	REV	2012-JUN-1	BEM
TGB	B	TYP	2011-OCT-17	BEM
TGB	A	INITIAL RELEASE	2011-SEP-20	BEM
DRAWN BY	REV	DESCRIPTION	DATE	APPROVED